

Installation instructions for 2007-2018 Jeep JK/JKU front frame chop tube bumper.

Thank you for purchasing our Jeep JK front frame chop tube bumper!

Installation notes:

- Removal of a portion of the factory frame is required.
- Removal of the factory crash bar is required
- Most winches will require that the solenoid pack be relocated
- If equipped, the vacuum pump will need to be relocated
- Refer to your factory service manual for any information regarding the removal of any factory components
- We recommend test fitting all components before painting or powder coating
- Holes have been provided to install aftermarket fog lights in the bumper behind the two outer dimpled holes, we recommend two 3"X3" LED pod lights

Tools Required:

- Various hand tools
- Appropriate metal cutting tool (Reciprocating saw, grinder with cut-off wheel, plasma cutter, torch etc.)
- Drill
- ½" Drill bit

Step 1:

Remove the existing front bumper on the Jeep.

Step 2:

If equipped, the vacuum pump will now need to be relocated. We recommend using our JK Vacuum Pump relocation kit (Part# B4WK0250)

Step 3:

The crash bar and vacuum pump bracket will need to be removed. Using an appropriate cutting tool, cut the crash bar and brackets off from the frame. Remove the parts highlighted below.

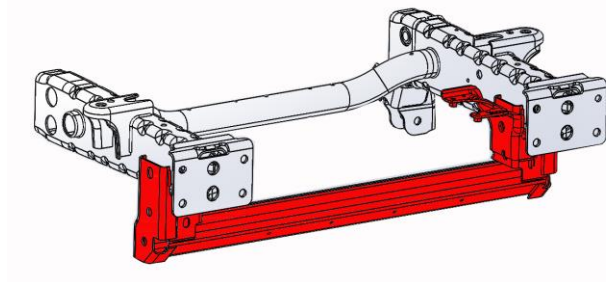

Step 4:

It is now time to trim the frame. A gauge has been supplied to mark the location to cut and drill the frame rails. Place the gauge on the frame with the arrow pointing up and the cut-out area against the inside and the bottom of the front body mount. Mark a line down the side of the frame along the front of the gauge and mark the location of the two holes. After marks have been made, cut the frame along the line on both sides. Place the bumper on the frame and verify that the four holes in the bumper line up with the four marks made on the frame. After the location of the mounting holes has been verified, remove the bumper and drill the 4 holes.

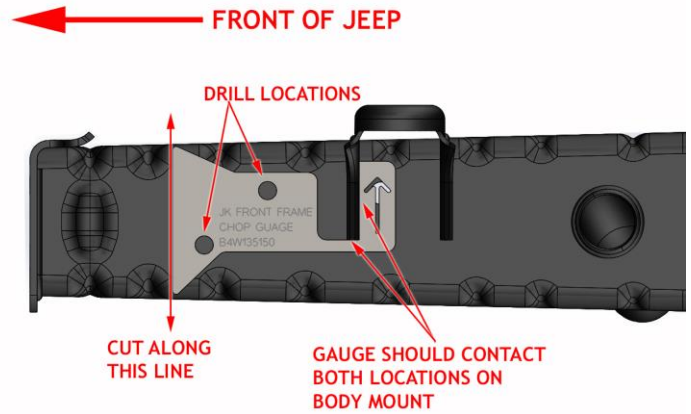

Step 5:

If installing a winch or lights they will need to be installed in the bumper now. The solenoid pack on most winches will need to be relocated for clearance to the grill on the Jeep. Refer to the manual for you particular model of winch for instruction for solenoid relocation.

Step 6:

After the winch and lights have been bolted to the bumper, test fit the bumper on the Jeep. Place the bumper on the Jeep so that the holes drilled in step 4 line up with the holes in the bumper. Install the 4 provided ½" bolts, and the 2 provided plates on the inside of either frame rail and install the provided locking nuts. Verify clearances to all components of the vehicle.

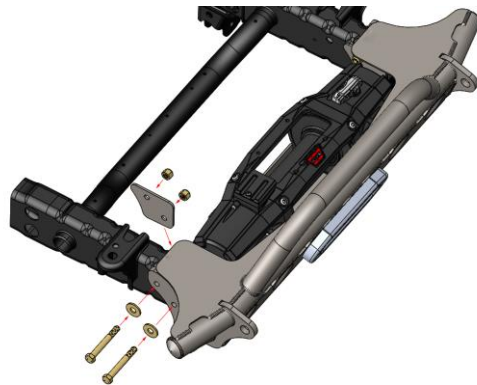

Step 7:

Remove the bumper from the Jeep, remove lights or winch if installed. Paint or powder coat the bumper and inner mounting plates the color of your choice.

Step 8:

Reinstall the winch and lights in the bumper and install the bumper on the Jeep with the provided hardware.

Congratulations you have completed the installation of your bumper!

Professional Services Disclaimer:

The content of all pages of this website (collectively, the "Website"), such as text, graphics, images, information and other material (collectively, "Content") is for informational purposes only. Any information furnished on this Website is not intended nor implied to be automotive advice and is not intended to replace personal consultation with a qualified automotive service technician, mechanic, or similar automotive professional.

Barnes 4WD has not examined the Content for accuracy, timeliness, completeness, appropriateness, or helpfulness. Barnes 4WD does not endorse any specific tests, products, procedures, opinions, or other information that may be mentioned on this Website. Your reliance upon information and Content obtained by you at or through this Website is solely at your own risk. IN NO EVENT SHALL BARNES 4WD BE LIABLE OR OTHERWISE RESPONSIBLE FOR ANY DAMAGE OR INJURY (INCLUDING DEATH) TO YOU, OTHER PERSONS, OR PROPERTY ARISING FROM ANY USE OF ANY PRODUCT, INFORMATION, IDEA, OR INSTRUCTION CONTAINED IN THE CONTENT.

BARNES 4WD DOES NOT MAKE ANY REPRESENTATION OR WARRANTY, EXPRESS OR IMPLIED, AT LAW OR IN EQUITY, WITH RESPECT TO ANY PRODUCT FEATURED ON THE WEBSITE, INCLUDING WITHOUT LIMITATION WITH RESPECT TO MERCHANTABILITY, FITNESS FOR ANY PARTICULAR PURPOSE, VALUE, VALIDITY, OR ENFORCEABILITY, AND ANY AND ALL SUCH OTHER REPRESENTATIONS OR WARRANTIES ARE HEREBY EXPRESSLY DISCLAIMED.